

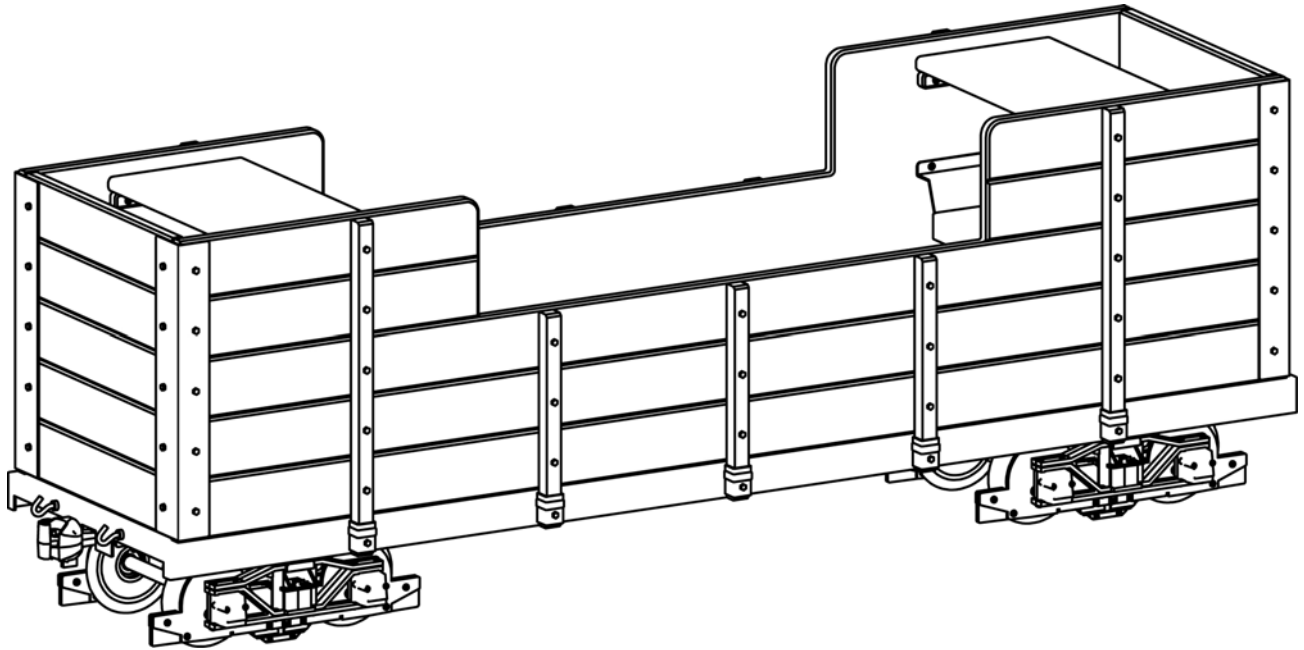

# THE GREAT AMERICAN TRAIN COMPANY



## Gondola Riding Car Owner's Manual

### IMPORTANT

You must carefully read this Manual before using The Great American Train Company Gondola Riding Car to avoid personal injury or property damage.



# Contents

---

Introduction.....	2
General Safety Information.....	2
Operation Safety Rules .....	4
Gondola Riding Car Operation.....	5
No-Tip Wear Pad Replacement .....	6
Storage & Cleaning .....	7
Specifications .....	8
Replacement Parts .....	8

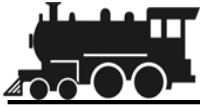

# Introduction

---

Congratulations on the purchase of your Great American Train Company (GATC), Gondola Riding Car.

If you have any questions concerning the product and its use, or if you feel your product is not working properly, contact The Great American Train Company at 763-476-5140, or visit our website at [www.greatamericantrain.com](http://www.greatamericantrain.com).

Read these Instructions carefully, making full use of all explanations and instructions. The “Know How” of trouble free operation of your railroad depends on the degree of your understanding of the system and willingness to keep all components in proper operating condition. Pay particular attention to all **NOTES**, **CAUTIONS**, and **WARNINGS** to avoid the risk of personal injury or property damage. It is important to understand that these **NOTES**, **CAUTIONS**, and **WARNINGS** are not exhaustive. The Great American Train Company cannot possibly know or evaluate all conceivable methods in which procedures may be performed, or the possible hazardous consequences of each method. Accordingly, anyone who uses a procedure that is not recommended by GATC assumes the risk of personal injury or property damage.

When unpacking your product, inspect each crate to ensure that no damage occurred during shipping. If damage has occurred during shipping, contact the shipper immediately. Remove all components from the shipping crates and inspect them. If any components are missing or damaged, contact The Great American Train Company immediately at 763-476-5140. Do not use or assemble the product if any components are damaged or missing. Do not use substitute components not manufactured by The Great American Train Company.



## General Safety Information

---

### **NOTE**

Notes are used to notify of installation, operation, or maintenance information that is important but not safety related.

### **CAUTION**

Caution without the Safety Alert Symbol is used to indicate the presence of a hazard, which if ignored may result in property damage.

### **CAUTION**

Caution with the Safety Alert Symbol is used to indicate the presence of a hazard, which if ignored may result in property damage and or minor personal injury.

### **WARNING**

Warning denotes that a potential hazard exists and indicates procedures that must be followed exactly to either eliminate or reduce the hazard, and to avoid serious personal injury, or prevent future safety problems with the product.

## General Safety Rules

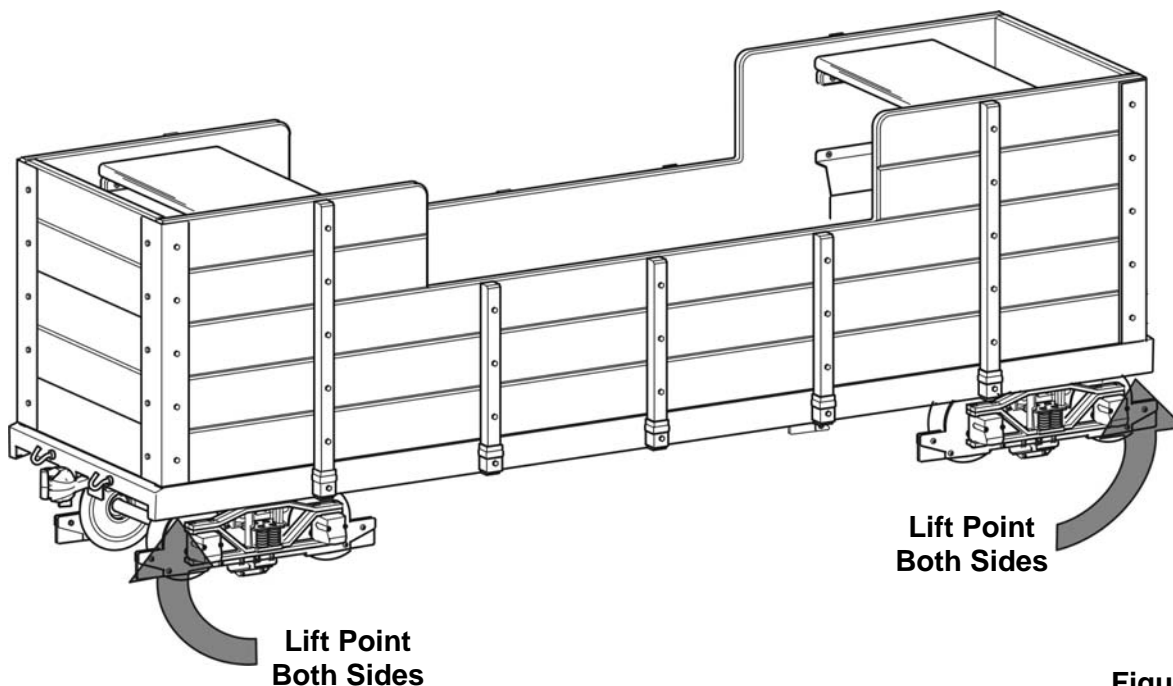

Figure 1

### **⚠ WARNING**

To lift the Gondola Riding Car requires two persons. Lift only at the locations indicated in Figure 1. It is recommended that you wear leather gloves while lifting since there are several sharp corners. Failure to wear leather gloves may result in cuts and increase the possibility of dropping the Gondola Riding Car, potentially causing damage and injury.

Do not attempt to rotate the wheels of the Gondola Riding Car. Your fingers or hand may get caught in the moving parts resulting in personal injury.

There are a number of sharp parts and corners on the Gondola Riding Car. Be careful when performing maintenance since these parts can result in injury due to your hands coming in contact with them.

Alterations to or modifications of the Gondola Riding Car are dangerous. Alteration or modification can result in parts having inadequate strength, leading to the risk of accidents resulting in serious, or in extreme cases, even fatal injury.



# Operation Safety Rules

---



**Please follow these important safety rules when you or others are operating the GATC Mogul (2-6-0) Steam Profile Locomotive and Gondola Riding Car. The Great American Train Company cannot foresee all situations that may arise; therefore, these rules are meant only as a general guideline to safe operation.**

- All passengers in GATC riding cars who are between the ages of two (2) and fifteen (15) must sit in the lower seats and must wear seatbelts. All GATC riding cars come equipped with seatbelts. If you are using a car from a source other than GATC, you assume the risk that serious personal injury may occur.
- Passengers must remain seated at all times and not shake or tilt the railcars.
- Hands and feet must remain in or on the Locomotive and/or railcars at all times.
- No scuffling, horseplay, grabbing at objects, or throwing of objects from the train.
- Passenger weight must be evenly distributed among multiple riding cars as well as within each individual car. Never load a riding car with passenger weight to the outside of the car.
- Pregnant women, obese persons, recent surgery patients, or those with balance difficulty are strongly advised not to ride the train.
- Operate the train at a safe speed not greater than three (3) mph. Trains carrying children, elderly or disabled persons should travel at speeds slower than normal. Slow down on curves and when passing through switches and grade crossings.
- Children under the age of two (2) should not ride the train. Children between the ages of two (2) and fifteen (15) should sit in front of a responsible adult.
- Make sure the track is clear of any persons or obstructions in front of or in back of the train.
- Make sure the train is fully stopped and the parking brake is engaged before loading or unloading passengers, and load or unload passengers at the flattest section of track possible. Passengers must never jump off the train while it is moving.
- Check that the batteries are sufficiently charged.
- Monitor and appropriately respond to error messages on the LCD screen on the control panel.
- Never allow others to operate the Locomotive unless they are properly trained and have read these instructions, cautions, warnings and other safety notices.
- Use and maintain safety chains between riding cars and rolling stock.
- For nighttime operation, the headlamp must be turned on.
- When coupling a passenger car to the Tender and carrying passengers on passenger cars, have a responsible adult sit in the very back position of the passenger car(s) to monitor the passengers. Have that person carry a whistle that is loud enough for the operator to hear. Should an impending danger occur, that person must blow the whistle to signal the operator to immediately stop the train.
- Maintain the track and track bed or confirm that the track upon which this Locomotive and/or Gondola Riding Car operates is properly maintained by others.
- Perform periodic maintenance on such items as chain tension and lubrication.



# Gondola Riding Car Operation

1. Place the Gondola Riding Car on the track with the wheels centered between the rails. Then, slide the Gondola Riding Car along the track until the wheels drop down on the rails. Once the wheels are on the rails, the No-Tip Safety Features will be engaged.



**Keep fingers clear of the Couplers while they are coming together. Failure to do so may result in pinched fingers and personal injury.**

2. The Couplers will automatically close and engage when used in conjunction with GATC cars. Most other brands of 1/8 scale cars will couple with GATC cars, but the Couplers may need to be closed manually.

The Coupler is released by pushing up on the Coupler Release Trigger located on the bottom of each Coupler (See Figure 2).

3. The Safety Chains provided with every GATC car must be used in conjunction with the Couplers (one Safety Chain on each side of the Coupler). These Safety Chains are designed to keep the cars connected in the rare event of a Coupler failure. Connect the Safety Chains as shown in Figure 3.

4. The GATC Gondola Riding Car has two seating positions: Adult and Child (for children fifteen (15) years of age and under). To set the Gondola Riding Car for Child seating, simply remove the Adult Seat by lifting it up and out, thus exposing the Child Seat (See Figure 4).

5. The Child Seats are equipped with Seatbelts and all children fifteen (15) years of age or under should wear them.

To connect the Seatbelts, simply snap the two ends together as shown in Figure 5; then, adjust the Seatbelt until it is snug around the waist of the child by pulling the end of the Seatbelt Strap on either end of the buckle, as shown in Figure 6.

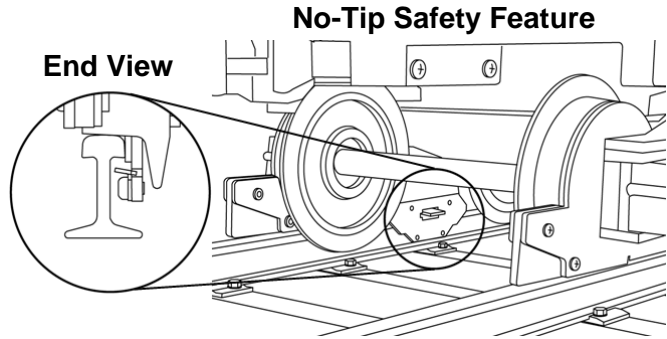

Figure 2

**Coupler Release Trigger**

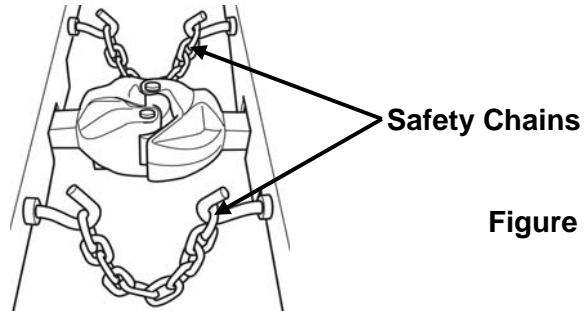
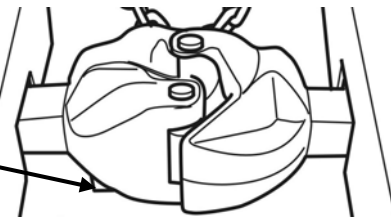

Figure 3

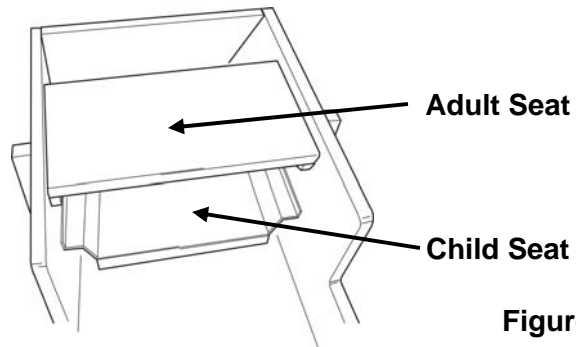

Figure 4

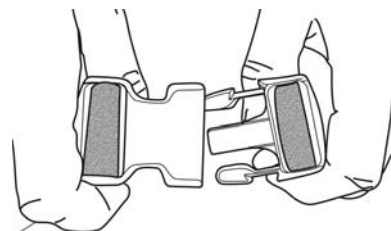

Figure 5

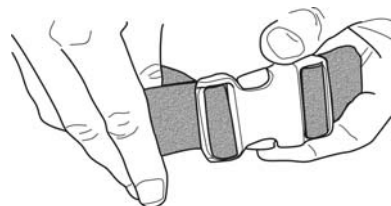

Figure 6



# No-Tip Wear Pad Replacement

## CAUTION

Visually inspect the No-Tip Wear Pads prior to each use of the Gondola Riding Car. When the No-Tip Wear Pads are worn to 25 percent of their original thickness, the No-Tip Wear Pads must be replaced.

## NOTE

No-Tip Wear Pad Replacement Kit (SKU 042601) consists of four (4) No-Tip Wear Pads plus a container of thread-locking compound.

## Required Tools



Small Phillips  
Screwdriver



Wire Hook  
(Formed from  
paper clip)

## Removing Gondola Riding Car from Track

1. Disconnect the Safety Chains on each side of the Coupler (See Figure 7).

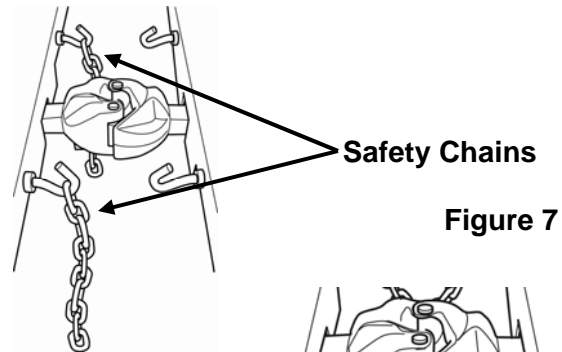

Figure 7

2. Release the Couplers by pushing up on the Coupler Release Trigger, located on the bottom of each Coupler (See Figure 8).



Figure 8

3. While lifting one side of the Gondola Riding Car, press down on either of the No-Tip Tabs on both trucks on the same side of the car to release the No-Tip features (See Figure 9).

When one side is released, slide the car away from the opposite side to release the remaining No-Tip hooks on the opposite side of the Gondola Riding Car.

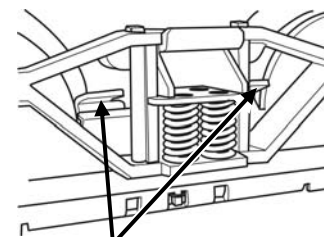

No-Tip  
Tabs

Figure 9

4. Remove the Gondola Riding Car from the Track.

## Replacing the No-Tip Wear Pad

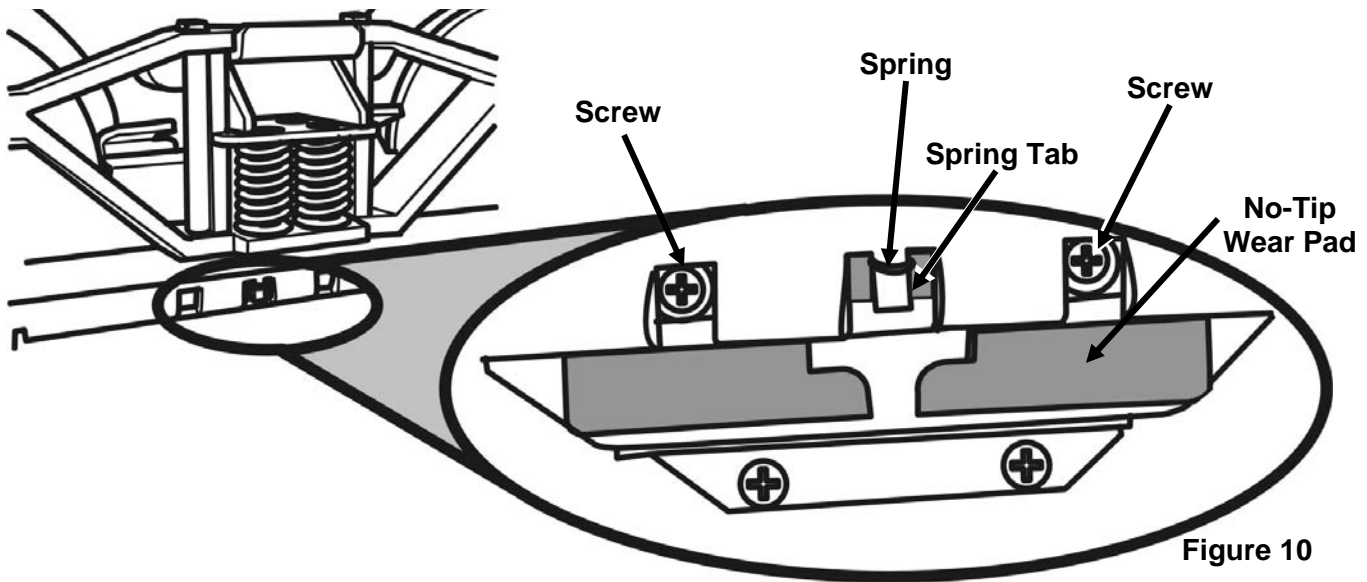

1. Slide the Spring down and off of the Spring Tab (See Figure 10).
2. Using the small Phillips screwdriver, remove the two (2) Screws securing the No-Tip Wear Pad (See Figure 10). A thread locking compound is used to secure the Screws. If the Screws are hard to remove, strike the end of the screwdriver with hammer to break the structure of the thread locking compound.
3. Remove the old No-Tip Wear Pad; then, slide a new No-Tip Wear Pad into place (See Figure 10).
4. Apply a drop of the thread locking compound provided with the No-Tip Wear Pad Kit to the Screws; then secure the new No-Tip Wear Pad with the two (2) Screws removed in Step 2 (See Figure 10).
5. Using the Wire Hook, pull the Spring back over the Spring Tab (See Figure 10).
6. Repeat Steps 1 through 5 on all four Trucks until all the worn No-Tip Wear Pads have been replaced.



## Storage & Cleaning

---

### Storage

When not in use, store your GATC Gondola Riding Car in a clean and dry location that is protected from the elements. Either in your garage or in a storage shed is recommended.

---

### Cleaning

A clean damp cloth is recommended to clean your GATC Gondola Riding Car. If a garden hose is used, care must be taken not to spray water directly at the Truck Assemblies as this may result in corrosion and premature failure of the wheel bearings.



# Specifications

---

## Gondola Riding Car

**Dimensions:** 20.9 in. H x 16.9 in. W x 64.9 in. L (531mm H x 429mm W x 1648mm L)

**Scale:** 1/8 (7.5 in. gauge)

**Weight:** 116 lbs. (53 kg)

---



# Replacement Parts

---

All of our products are modular in design. This means if you need to replace a spare part or two in the coming years, you can easily install them on-site.

For more information concerning replacement parts or to order replacement parts, contact The Great American Train Company at 763-476-5140.

No-Tip Wear Pad Replacement Kit (SKU 042601) consists of four (4) No-Tip Wear Pads, plus a container of thread locking compound.

Replacement Adult Seat (SKU 680157) consists of one adult seat and all necessary mounting hardware.



**The Great American Train Company, LLC**  
**Two Carlson Parkway North**  
**Plymouth, Minnesota 55447 U.S.A.**  
**Phone: 763-476-5140**  
**FAX: 763-475-6677**  
**Website: [www.greatamericantrain.com](http://www.greatamericantrain.com)**

© 2008 The Great American Train Company, LLC. All rights reserved. Great American Train is a trademark of The Great American Train Company, LLC. All other trademarks are the property of their respective companies. Specifications are subject to change without notice.